

ELECTROFUSION
ELBOWS

MOLDED
FOR YOUR
INDUSTRY

IntegriFuse™



 **INTEGRITY**
Fusion Products, Inc.

TOLL FREE 1-888-770-6330

INTEGRITYFUSION.COM

The difference MOLDED Makes

Integrity Fusion continues to be the market leader in electrofusion fittings, by offering innovative solutions to all of your fusible needs. Our IntegriFuse brand EF 90's & 45's are molded in sizes up through 8" IPS and fully pressure rated to SDR 11. Electrofusion Elbows offer a convenient alternative to traditional butt fusion when dealing with tight spaces, repairs, vertical applications, or any project when difficult to utilize butt fusion equipment.

IntegriFuse EF Fittings are manufactured from the highest quality black high density bimodal polyethylene copolymer resin designed for use in, but not limited to, potable water, natural gas, industrial, landfill, oil & gas, and mining applications.

All IntegriFuse fittings meet ASTM -D2513 & ASTM D3261 (where applicable)

Integrity Fusion Products, Inc.
270 Parkade Court
Peachtree City, GA 30269
P: 1-888-770-6330 • P: 770-632-7530
F: 770-632-7540
E: Info@IntegrityFusion.com

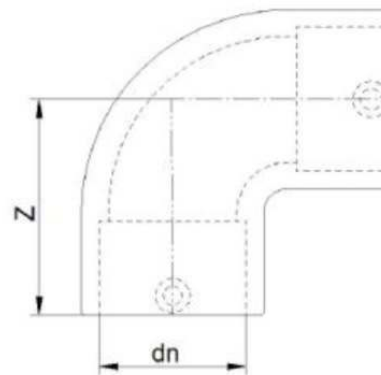

Electrofusion 90° Elbow - (Standard Dimension Ratio) 125 PSI (Working Pressure at 73.4° F)

| Nominal Size | OD | Z | Unit Weight | Item Code |
|--------------|--------|-------|-------------|-----------|
| 4" IPS | 4.500" | 5.9" | 6.6 lbs. | 200156 |
| 6" IPS | 6.625" | 8.4" | 9.2 lbs. | 200157 |
| 8" IPS | 8.625" | 10.0" | 21.8 lbs. | 200158 |

Water - 200 PSI (ASTM) / 232 PSI (ISO) | Gas - 100 PSI @ 73° F Sustainable Maximum Operating Pressure
Suitable for use on IPS SDR 11 to SDR 17 HDPE Pipe

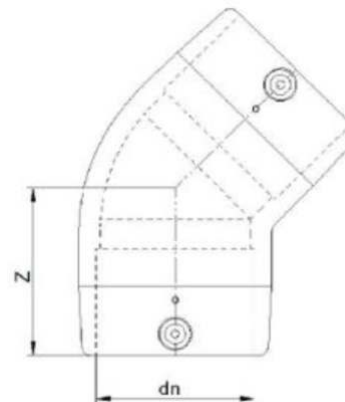

Electrofusion 45° Elbow - (Standard Dimension Ratio) 125 PSI (Working Pressure at 73.4° F)

| Nominal Size | OD | Z | Unit Weight | Item Code |
|--------------|--------|------|-------------|-----------|
| 2" IPS | 2.375" | 2.7" | 0.9 lbs. | 200054 |
| 3" IPS | 3.500" | 3.7" | 2.1 lbs. | 200055 |
| 4" IPS | 4.500" | 4.7" | 5.7 lbs. | 200056 |
| 6" IPS | 6.625" | 6.3" | 8.5 lbs. | 200057 |
| 8" IPS | 8.625" | 8.0" | 18.5 lbs. | 200058 |

Water - 200 PSI (ASTM) / 232 PSI (ISO) | Gas - 100 PSI @ 73° F Sustainable Maximum Operating Pressure - Designed for use on IPS SDR 11 to SDR 17 HDPE Pipe

Manufactured in accordance to ASTM 1055

Manufactured with resin having a material designation code of PE3408 / PE4710 / PE100 resin to comply to ASTM D3350. AWWA C901/901 NSF/ANSI 61

