

60° BEVELED
FLANGE
ADAPTERS

MOLDED
FOR YOUR
INDUSTRY

IntegriFuse™



 **INTEGRITY**
Fusion Products, Inc.

TOLL FREE 1-888-770-6330

INTEGRITYFUSION.COM

The difference MOLDED Makes

Molded Flange Adapters from Integrity Fusion Products have quickly become a market leader. By injection molding our flange adapters, we offer a high quality and consistent product every time. The self sealing design on the hub face eliminates the need for a gasket for most applications.

IntegriFuse Fittings are manufactured from the highest quality black high density bimodal polyethylene copolymer designed for use in, but not limited to, potable water, natural gas, industrial, landfill, oil & gas, and mining applications.

All IntegriFuse fittings meet ASTM –D2513 & ASTM D3261 (where applicable).
FM Approved.

Integrity Fusion Products, Inc.
270 Parkade Court
Peachtree City, GA 30269
P: 1-888-770-6330 • P: 770-632-7530
F: 770-632-7540
E: Info@IntegrityFusion.com

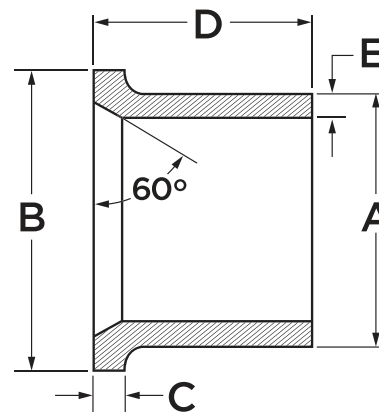

Beveled SDR 11 - (Standard Dimension Ratio) 200 PSI (Working Pressure at 73.4° F)

Nominal Size	A	B	C	D	E	Weight	Item Code	Notes
2" IPS	2.375"	3.94"	0.57"	5.71"	0.216"	0.50 lbs.	100470	-
3" IPS	3.500"	5.00"	0.76"	5.82"	0.318"	1.00 lbs.	100472	-
4" IPS	4.500"	6.00"	1.17"	6.54"	0.409"	2.15 lbs.	100474	-