

BLAST PROTECTORS

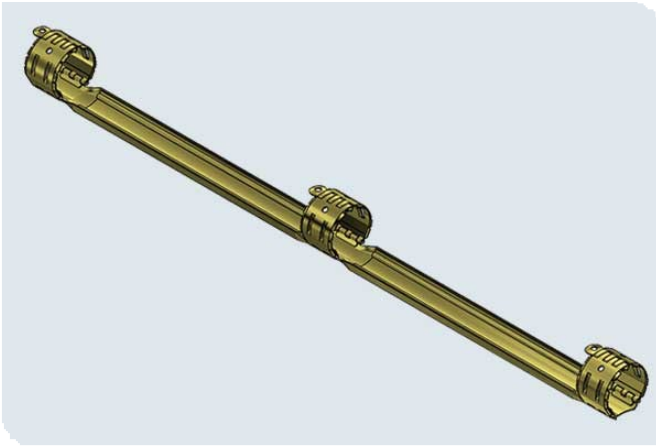

KEY FEATURES

- ✓ Long length for secure protection
- ✓ Added metal in the channel for orientation locating
- ✓ Multiple collars for secure attachment

Slingco Blast Protectors are designed to protect the cables servicing perforating guns in wells. We offer added metal in the protector channel to enhance locating the orientation of the gun through magnetic resonance. Protector styles are long length (56" to 96") with added collars for securing the protector to the tubing. Call Slingco and let us to design a protector perfect for your application.

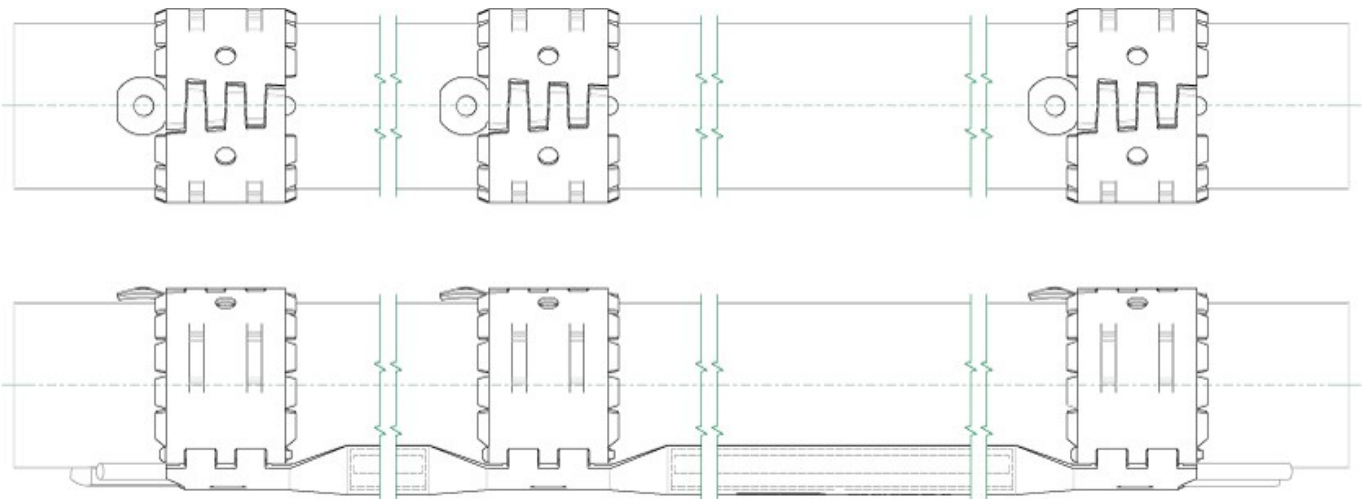

L9, 1 York Street, Sydney, NSW 2000, Australia Sales: +61 3 8840 6556

GET IN TOUCH



+61 3 8840 6556



sales@slingcoaustralia.com.au